

STEPHAN Universal Machine UMSK 24



Model STEPHAN UMSK 24 (possibly with optional accessories)

Advantages:

- › Flexible and multifunctional
- › Short batch times
- › Economic processing
- › Operator friendly
- › Homogenous mixing
- › Efficient cutting
- › Stable emulsions
- › Configurable for many different applications

Typical Applications:

- › Processed chesse
- › Ganache
- › Fillings (sweet & spicy)
- › Pastes
- › Hummus
- › Fruit preparations
- › Mayonnaise, Ketchup
- › Marzipan

Standard Execution:

- › Processing temperature 95 °C
- › Main motor 300 – 3000 rpm
- › Soft touch keyboard FT 3011 for manual operation
- › Manually operated lid opening / closing
- › Automatically operated mixing baffle
- › Manually operated bowl tilting
- › Double jacket, water / steam
- › Direct steam injection
- › Discharge connection with blind stopper
- › Pneumatically operated dosing valve
- › Vacuum unit

Options:

- › Processing temperature 125 °C
- › Siemens PLC, operator panel TP 700
- › Water ring vacuum pump
- › Water dosing device
- › Funnel for dosing connection
- › Sight glass DN 80 with lamp and wiper
- › Pneumatically operated discharge valve DN 65
- › Steam filter station
- › Manually or pneumatically operated condenser unit
- › Data recording via USB stick
- › Wide range of working tools

STEPHAN Universal Machine UMSK 24

Dimensions UMSK 24

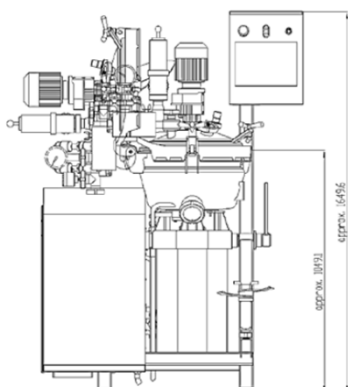

Overall height: approx. 1650 mm

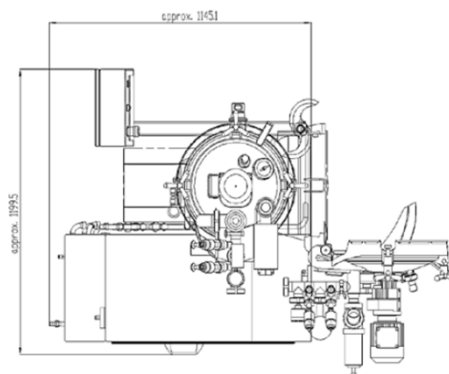

Machine Data: (depending on options)

Bowl content, approx.	(l)	30
Batch size (depending on product)	(l)	18
Net weight, approx.	kg	320
Max. operating temperature – bowl (option)	°C	95 (125)
Max. operating pressure – bowl (option)	bar g	0.0 (1.5)
Max. operating temperature – double jacket	°C	133
Max. operating pressure – double jacket	bar g	2.0
Material: product side		1.4301 (AISI 304) or similar
non-product side		1.4301 (AISI 304) or similar
Shaft seals: main motor		sealing rings
gear motor		sealing rings
Connections: compressed air, pneumatic connection		8 mm
steam supply		½", socket
water supply		DN 15, hose connector

Energy requirement: (depending on options)

Operating voltage / rated current	(protection)	V/Hz/A	400/50/19, (slow)
Operating voltage / rated current	(protection)	V/Hz/A	220/60/35, (slow)
Drives:	main motor	kW	7.5
	gear motor	kW	0.37
	vacuum pump (option)	kW	0.75 (50 Hz) 1.1 (60 Hz)
Steam:	theoretical requirement	kg/h	75
	recommended supply	kg/h	85
	steam supply pressure	bar g	4 – 8
	steam pressure machine	bar g	2.0 for double jacket
	steam pressure machine	bar g	1 – 3 for steam nozzle
Water:	water supply pressure, max.	bar g	2.0
	water supply – recipe, approx.	l/min	20
	water supply vacuum pump, approx.	l/h	240
	water supply – double jacket	l/h	750